

# PRODUCT INFORMATION PACKET

**marathon**<sup>®</sup>  
Motors

Model No: SCA3P72A3131GAAD01

Catalog No: SCA3P72A3131GAAD01

3.7kW, General Purpose Low Voltage IEC Motor, 3 phase, 4 Pole, 415V, B5, 50Hz, 86.3%, 112M Frame, TEFC  
Cast Iron IE2 Efficiency Motors



Regal and Marathon are trademarks of Regal Beloit Corporation or one of its affiliated companies.  
©2020 Regal Beloit Corporation, All Rights Reserved. MC017097E

**REGAL**



### Nameplate Specifications

Output HP	5 Hp	Output KW	3.7 kW
Frequency	50 Hz	Voltage	415 V
Current	7.0 A	Speed	1451 rpm
Service Factor	1	Phase	3
Efficiency	86.3 %	Power Factor	0.85
Duty	S1	Insulation Class	F
Frame	112M	Enclosure	Totally Enclosed Fan Cooled
Ambient Temperature	50 °C	Drive End Bearing Size	6306
Opp Drive End Bearing Size	6206	UL	No
CSA	No	CE	Yes
IP Code	55		

### Technical Specifications

Electrical Type	Squirrel Cage	Starting Method	Direct On Line
Poles	4	Rotation	Bi-Directional
Mounting	B35	Motor Orientation	Horizontal
Drive End Bearing	2z-C3	Opp Drive End Bearing	2z-C3
Frame Material	Cast Iron	Shaft Type	Keyed
Overall Length	399 mm	Frame Length	174 mm
Shaft Diameter	28 mm	Shaft Extension	60 mm
Assembly/Box Mounting	TOP		
Outline Drawing	0211200556	Connection Drawing	8442000085

This is an uncontrolled document once printed or downloaded and is subject to change without notice. Date Created:16/01/2020

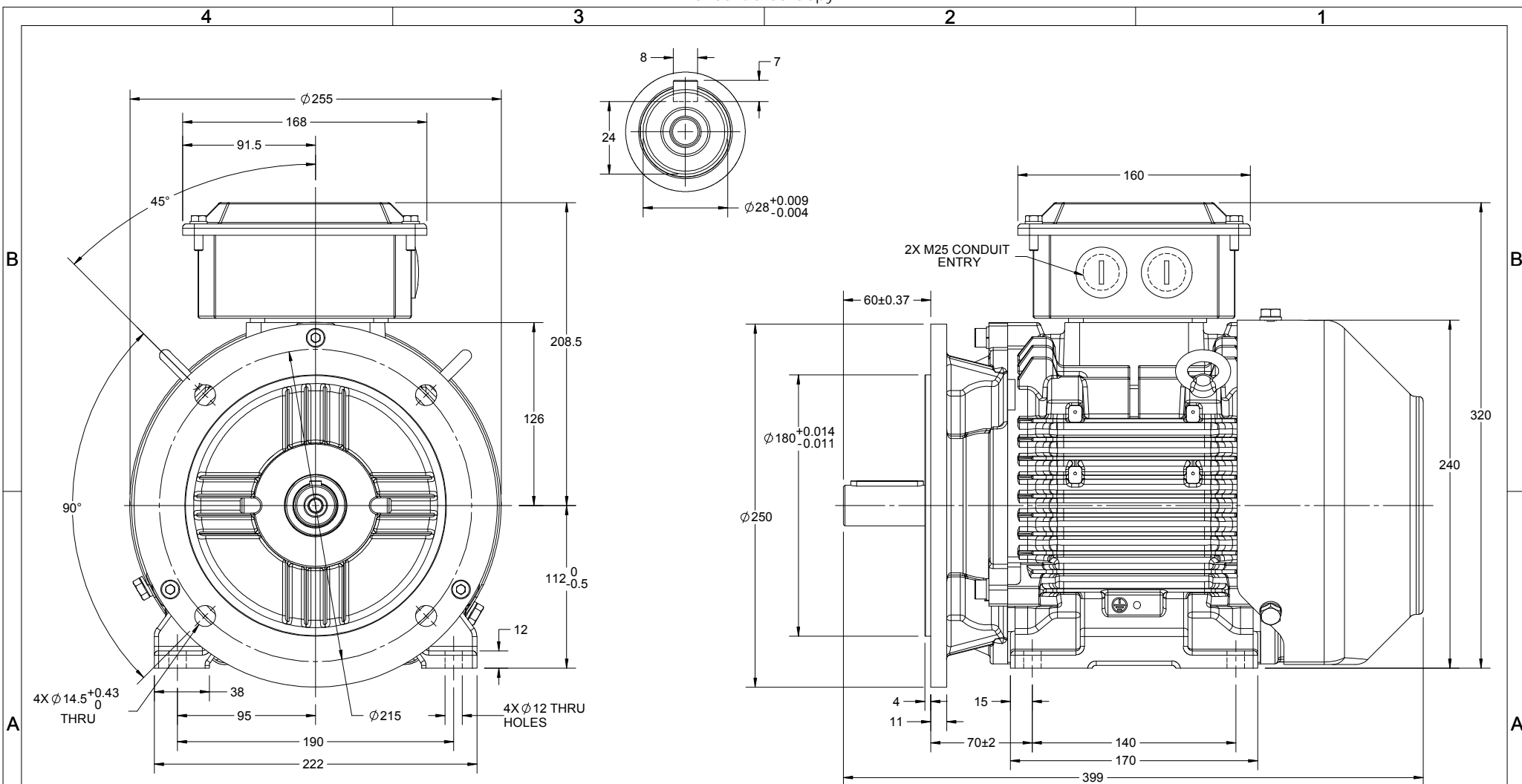

DRAWING REVISION B	REVISION BY LK	DATE 29/05/2019
ECO ECO-0167983	APPROVED BY JAY	DATE 29/05/2019
ECO DESCRIPTION MODEL UPDATED AS PER NEW 3D STRUCTURE <small>COPYRIGHT REGAL BELOIT AMERICA, INC. ALL RIGHTS RESERVED.                  PROPRIETARY AND CONFIDENTIAL INFORMATION - THIS DOCUMENT IS THE PROPERTY OF                  REGAL BELOIT AMERICA, INC. (OWNER) AND CONTAINS OWNER'S PROPRIETARY                  INFORMATION. ANY PERSON, CORPORATION OR OTHER FIRM RECEIVING IT IS DEEMED,                  BY RECEIVING IT, TO AGREE THAT IT, AND/OR ANY PART OF IT, SHALL NOT BE DISCLOSED                  TO ANY PERSON, CORPORATION OR OTHER ENTITY, DUPLICATED, AND/OR USED, EXCEPT                  AS EXPRESSLY APPROVED IN WRITING IN ADVANCE BY OWNER. THIS DOCUMENT SHALL                  BE RETURNED TO OWNER UPON REQUEST. IT MAY BE SUBJECT TO CERTAIN                  RESTRICTIONS UNDER APPLICABLE EXPORT CONTROL LAWS AND REGULATIONS.</small>		

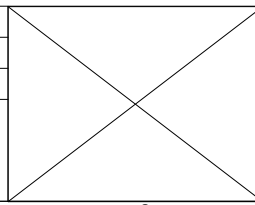

DRAWN BY PRIYA
DATE 27/03/2018
APPROVED BY JAY
DATE 27/03/2018
REFERENCE
THIRD ANGLE PROJECTION

<b>marathon</b> Motors	
DESCRIPTION <b>OUTLINE</b> 112 FR.- B35 MTG. MOTOR TYPE: SCA	
MATERIAL	PROCESS/FINISH
SIZE B	DRAWING NUMBER 0211200556
	SHEET 1 OF 1

COPYRIGHT REGAL BELOIT AMERICA, INC. ALL RIGHTS RESERVED. **Unapproved Copy**  
 PROPRIETARY AND CONFIDENTIAL INFORMATION - THIS DOCUMENT IS THE PROPERTY OF  
 REGAL BELOIT AMERICA, INC. ("OWNER") AND CONTAINS OWNER'S PROPRIETARY  
 INFORMATION. ANY PERSON, CORPORATION OR OTHER FIRM RECEIVING IT IS DEEMED  
 BY RECEIVING IT TO AGREE THAT IT AND/OR ANY PART OF IT SHALL NOT BE DISCLOSED  
 TO ANY PERSON, CORPORATION OR OTHER ENTITY, DUPLICATED, AND/OR USED, EXCEPT  
 AS EXPRESSLY APPROVED IN WRITING IN ADVANCE BY OWNER. THIS DOCUMENT SHALL  
 BE RETURNED TO OWNER UPON REQUEST. IT MAY BE SUBJECT TO CERTAIN  
 RESTRICTIONS UNDER APPLICABLE EXPORT CONTROL LAWS AND REGULATIONS.

DRAWING REVISION	REVISION BY	DATE
A	SN	13/01/2017
ECO-0116390	APPROVED BY SBD	DATE 13/01/2017
ECO DESCRIPTION NEW DRAWING RELEASE		

GEOMETRIC TOLERANCE		
LINEAR DIM	>0-6	±0.1
	>6-30	±0.2
	>30-120	±0.3

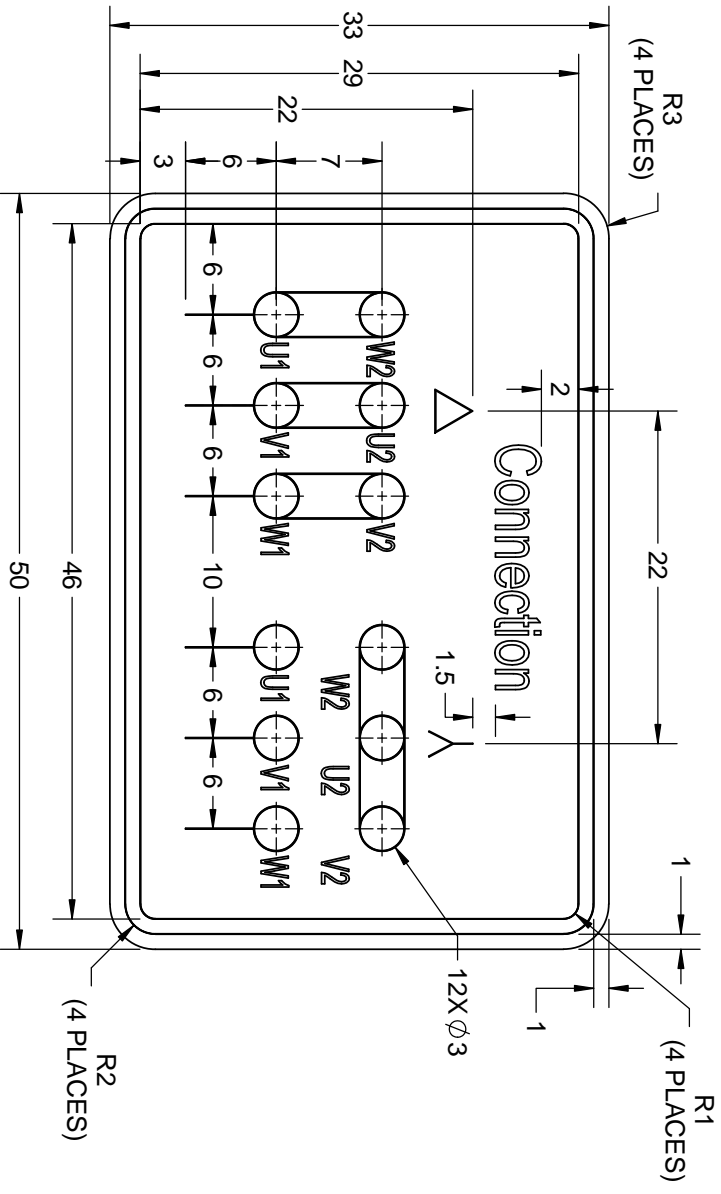

- NOTES:
1. PRESSURE-SENSITIVE ADHESIVE COATED PAPER ON THE BACK OF SELF-ADHESIVE.
  2. AT THE END OF YELLOW, WORDS, SYMBOLS, LETTERS ARE BLACK, BORDER IS BLACK.
  3. THE TOLERANCE OF THE LINEAR SIZE OF THE TOLERANCE WITHOUT THE TOLERANCE BY THE TABLE.

8WD.442.2017

DRAWN BY SN		DESCRIPTION <b>REGAL</b> ™ Regal Beloit America, Inc. CONN DIAGRAM-NAMEPLATE	
DATE 16/12/2016	APPROVED BY SBD	MATERIAL	PROCESS/FINISH
DATE 16/12/2016	REFERENCE	SIZE A	DRAWING NUMBER 8442000085
THIRD ANGLE PROJECTION		SIZE A	DRAWING NUMBER 8442000085
		SHEET 1 OF 1	



Model No. SCA3P72A3131GAAD01

U (V)	Δ / Y Conn	f (Hz)	P		I [A]	n [RPM]	T [Nm]	IE Class	% EFF at __ load				PF at __ load			I <sub>w</sub> /I <sub>N</sub> [pu]	T <sub>k</sub> /T <sub>N</sub> [pu]	T <sub>k</sub> /T <sub>N</sub> [pu]
			[kW]	[hp]					S/4FL	FL	3/4FL	1/2FL	FL	3/4FL	1/2FL			
415	Δ	50	3.7	5.0	7.0	1451	24.64	IE2	-	86.3	86.3	86.5	0.85	0.79	0.66	6.5	2.5	2.9

Motor type	SCA	Degree of protection	IP 55
Enclosure	TEFC	Mounting type	IM B35
Frame Material	Cast Iron	Cooling method	IC 411
Frame size	112M	Motor weight - approx.	50 kg
Duty	S1	Gross weight - approx.	53 kg
Voltage variation *	± 10%	Motor inertia	0.0145 kgm <sup>2</sup>
Frequency variation *	± 5%	Load inertia	Customer to Provide
Combined variation *	10%	Vibration level	1.6 mm/s
Design	N	Noise level ( 1meter distance from motor)	64 dB(A)
Service factor	1.0	No. of starts hot/cold/Equally spread	2/3/4
Insulation class	F	Starting method	DOL
Ambient temperature	-20 to +50 °C	Type of coupling	Direct
Temperature rise (by resistance)	70 [ Class B ] K	LR withstand time (hot/cold)	6/10 s
Altitude above sea level	1000 meter	Direction of rotation	Bi-directional
Hazardous area classification	NA	Standard rotation	Clockwise form DE
Zone classification	NA	Paint shade	RAL 5014
Gas group	NA	Accessories	
Temperature class	NA	Accessory - 1	-
Rotor type	Aluminum Die cast	Accessory - 2	-
Bearing type	Anti-friction ball	Accessory - 3	-
DE / NDE bearing	6306-2Z / 6206-2Z	Terminal box position	TOP
Lubrication method	Greased for life	Maximum cable size/conduit size	1R x 3C x 16mm <sup>2</sup> /2 x M25 x 1.5
Type of grease	NA	Auxiliary terminal box	NA

I<sub>w</sub>/I<sub>N</sub> - Locked Rotor Current / Rated Current

T<sub>k</sub>/T<sub>N</sub> - Breakdown Torque / Rated Torque

T<sub>k</sub>/T<sub>N</sub> - Locked Rotor Torque / Rated Torque

**NOTE**

All performance values at rated voltage and frequency.

All performance parameters are subjected to standard tolerance as per IEC 60034-1

\* Voltage, Frequency and combine variation are as per IEC60034-1

Technical data are subject to change. There may be discrepancies between calculated and name plate values.

Efficiency Standards	Europe	China	India	Aus/Nz	Brazil	Global IEC
	-	-	IS 12615 : 2018	-	-	-





Model No. SCA3P72A3131GAAD01

Enclosure	U [V]	Δ / Y Conn	f [Hz]	P [kW]	P [hp]	I [A]	n [RPM]	T [kgm]	T [Nm]	IE Class	Amb [°C]	Duty	Elevation [m]	Inertia [kg·m <sup>2</sup> ]	Weight [kg]
TEFC	415	Δ	50	3.7	5.0	7.0	1451	2.51	24.64	IE2	50	S1	1000	0.0145	50

**Motor Load Data**

Load Point		NL	1/4FL	1/2FL	3/4FL	FL	5/4FL
Current	A	3.2	3.5	4.7	5.9	7.0	
Torque	Nm	0.0	6.0	12.1	18.2	24.6	
Speed	r/min	1500	1489	1477	1465	1451	
Efficiency	%	0.0	80.8	86.5	86.3	86.3	
Power Factor	%	8.8	46.0	66.3	78.8	84.7	

**Performance vs Load Chart**

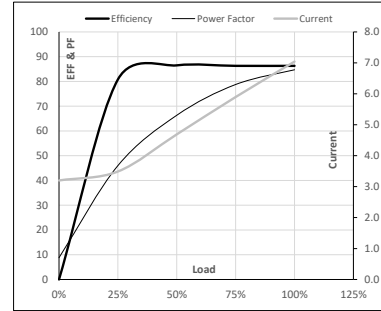

**Motor Speed Torque Data**

Load Point		LR	P-Up	BD	Rated	NL
Speed	r/min	0	300	1090	1451	1500
Current	A	45.8	41.2	30.6	7.0	3.2
Torque	pu	2.5	2.1	2.9	1	0

**Starting Characteristics Chart**

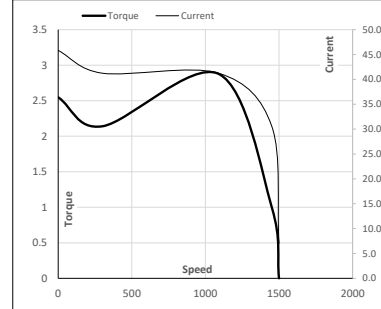

**NOTE** Refer data sheet for applicable standard and tolerances on performance parameters

Issued By  
Issued Date





Model No. SCA3P72A3131GAAD01

Enclosure	U (V)	$\Delta / Y$ Conn	f [Hz]	P [kW]	P [hp]	I [A]	n [rpm]	T [kgm]	T [Nm]	IE Class	Amb [°C]	Duty	Elevation [m]	Inertia [kg·m <sup>2</sup> ]	Weight [kg]
TEFC	415	$\Delta$	50	3.7	5.0	7.0	1451	2.51	24.64	IE2	50	S1	1000	0.0145	50

**Motor Speed Torque Data**

Load	FL	$I_1$	$I_2$	$I_3$	$I_4$	$I_5$	LR
TWT Hot	s 10000	25	13	11	10	8	6
TWT Cold	s 10000	45	22	18	15	13	10
Current	pu	1	2	3	4	4.5	5
							6.5

**Thermal Characteristics Chart**

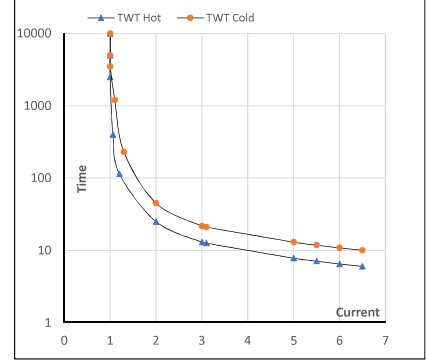

**NOTE** Refer data sheet for applicable standard and tolerances on performance parameters

Issued By  
Issued Date

