

# PRODUCT INFORMATION PACKET

**marathon**<sup>®</sup>  
Motors

Model No: TCA0452A3133GACD01

Catalog No: TCA0452A3133GACD01

45.0 kW General Purpose Low Voltage IEC Motor, 3 phase, 1500 RPM, 415 V, 225M Frame, TEFC  
Cast Iron IE3 Efficiency Motors



Regal and Marathon are trademarks of Regal Beloit Corporation or one of its affiliated companies.  
©2020 Regal Beloit Corporation, All Rights Reserved. MC017097E

**REGAL**



### Nameplate Specifications

Output HP	<b>60 Hp</b>	Output KW	<b>45.0 kW</b>
Frequency	<b>50 Hz</b>	Voltage	<b>415 V</b>
Current	<b>77.3 A</b>	Speed	<b>1484 rpm</b>
Service Factor	<b>1</b>	Phase	<b>3</b>
Efficiency	<b>94.2 %</b>	Power Factor	<b>0.86</b>
Duty	<b>S1</b>	Insulation Class	<b>F</b>
Frame	<b>225M</b>	Enclosure	<b>Totally Enclosed Fan Cooled</b>
Ambient Temperature	<b>50 °C</b>	Drive End Bearing Size	<b>6313</b>
Opp Drive End Bearing Size	<b>6213</b>	UL	<b>No</b>
CSA	<b>No</b>	CE	<b>Yes</b>
IP Code	<b>55</b>		

### Technical Specifications

Electrical Type	<b>Squirrel Cage</b>	Starting Method	<b>Direct On Line</b>
Poles	<b>4</b>	Rotation	<b>Bi-Directional</b>
Mounting	<b>B35</b>	Motor Orientation	<b>Horizontal</b>
Drive End Bearing	<b>C3</b>	Opp Drive End Bearing	<b>C3</b>
Frame Material	<b>Cast Iron</b>	Shaft Type	<b>Keyed</b>
Overall Length	<b>862 mm</b>	Frame Length	<b>425 mm</b>
Shaft Diameter	<b>60 mm</b>	Shaft Extension	<b>140 mm</b>
Assembly/Box Mounting	<b>R Side</b>		
Outline Drawing	<b>0222500784</b>	Connection Drawing	<b>8442000085</b>

This is an uncontrolled document once printed or downloaded and is subject to change without notice. Date Created:06/01/2020

4

3

Uncontrolled Copy

2

1

B

B

A

A

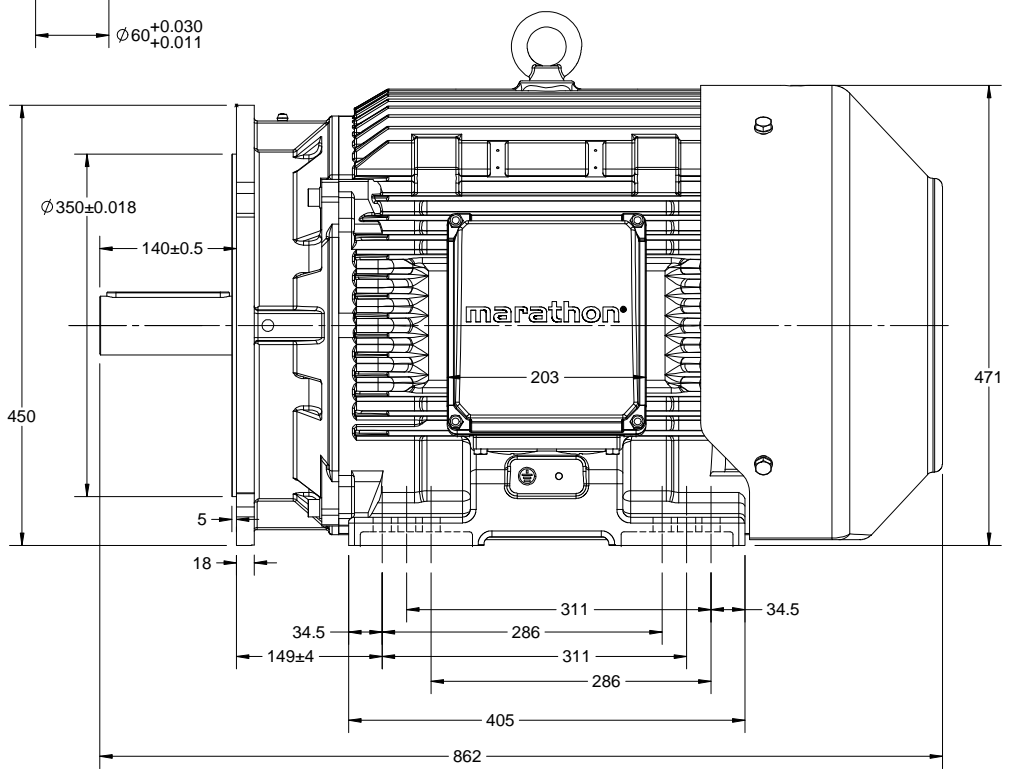
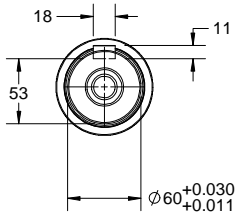
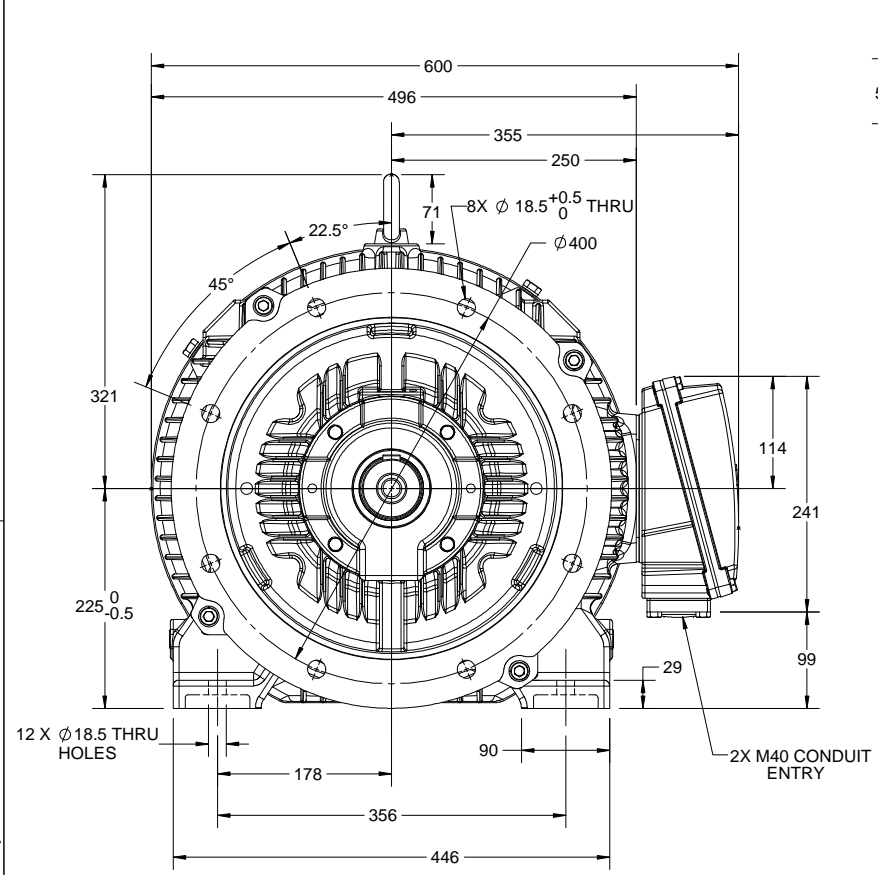

DRAWING REVISION B	REVISION BY VS	DATE 09/08/2018
ECO ECO-0148344	APPROVED BY SBD	DATE 09/08/2018
ECO DESCRIPTION MODEL UPDATED		
<small>COPYRIGHT REGAL BELOIT AMERICA, INC. ALL RIGHTS RESERVED.          PROPRIETARY AND CONFIDENTIAL INFORMATION - THIS DOCUMENT IS THE PROPERTY OF          REGAL BELOIT AMERICA, INC. (OWNER) AND CONTAINS OWNER'S PROPRIETARY          INFORMATION. ANY PERSON, CORPORATION OR OTHER FIRM RECEIVING IT IS DEEMED,          BY RECEIVING IT, TO AGREE THAT IT, AND/OR ANY PART OF IT, SHALL NOT BE DISCLOSED          TO ANY PERSON, CORPORATION OR OTHER ENTITY, DUPLICATED, AND/OR USED, EXCEPT          AS EXPRESSLY APPROVED IN WRITING IN ADVANCE BY OWNER. THIS DOCUMENT SHALL          BE RETURNED TO OWNER UPON REQUEST. IT MAY BE SUBJECT TO CERTAIN          RESTRICTIONS UNDER APPLICABLE EXPORT CONTROL LAWS AND REGULATIONS.</small>		

DRAWN BY UDAY	Regal Beloit America, Inc.
DATE 16/08/2016	
APPROVED BY SBD	DESCRIPTION <b>OUTLINE</b> 225M FR 4-8P-B35 MTG TYPE: TCA/QCA-RHS TB
DATE 16/08/2016	MATERIAL
REFERENCE	PROCESS/FINISH
THIRD ANGLE PROJECTION	SIZE B
	DRAWING NUMBER <b>0222500784</b>
	SHEET 1 OF 1

4

3

2

1

COPYRIGHT REGAL BELOIT AMERICA, INC. ALL RIGHTS RESERVED. This is an Unapproved Copy  
 PROPRIETARY AND CONFIDENTIAL INFORMATION - THIS DOCUMENT IS THE PROPERTY OF  
 REGAL BELOIT AMERICA, INC. (OWNER) AND CONTAINS OWNER'S PROPRIETARY  
 INFORMATION. ANY PERSON, CORPORATION OR OTHER FIRM RECEIVING IT IS DEEMED  
 BY RECEIVING IT TO AGREE THAT IT AND/OR ANY PART OF IT SHALL NOT BE DISCLOSED  
 TO ANY PERSON, CORPORATION OR OTHER ENTITY, DUPLICATED, AND/OR USED, EXCEPT  
 AS EXPRESSLY APPROVED IN WRITING IN ADVANCE BY OWNER. THIS DOCUMENT SHALL  
 BE RETURNED TO OWNER UPON REQUEST. IT MAY BE SUBJECT TO CERTAIN  
 RESTRICTIONS UNDER APPLICABLE EXPORT CONTROL LAWS AND REGULATIONS.

DRAWING REVISION	REVISION BY	DATE
A	SN	13/01/2017
ECO-0116390	APPROVED BY SBD	DATE 13/01/2017
ECO DESCRIPTION NEW DRAWING RELEASE		

GEOMETRIC TOLERANCE		
LINEAR DIM	>0-6	±0.1
	>6-30	±0.2
	>30-120	±0.3

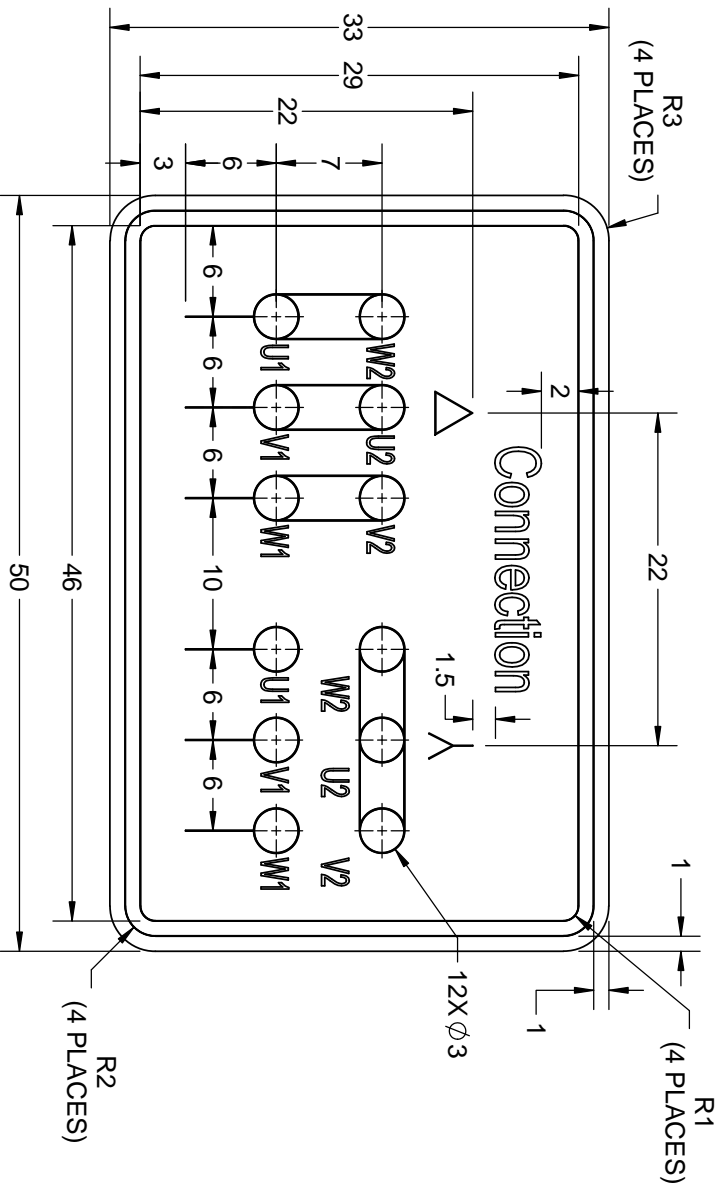

- NOTES:
1. PRESSURE-SENSITIVE ADHESIVE COATED PAPER ON THE BACK OF SELF-ADHESIVE.
  2. AT THE END OF YELLOW, WORDS, SYMBOLS, LETTERS ARE BLACK, BORDER IS BLACK.
  3. THE TOLERANCE OF THE LINEAR SIZE OF THE TOLERANCE WITHOUT THE TOLERANCE BY THE TABLE.

8WD.442.2017

DRAWN BY SN		DESCRIPTION <b>REGAL</b> <sup>TM</sup> Regal Beloit America, Inc. CONN DIAGRAM-NAMEPLATE	
DATE 16/12/2016		DATE 16/12/2016	
APPROVED BY SBD		MATERIAL	
DATE 16/12/2016		PROCESS/FINISH	
REFERENCE		SIZE A	
THIRD ANGLE PROJECTION		DRAWING NUMBER 8442000085	
		SHEET 1 OF 1	

Model No. TCA0452A3133GACD01

U (V)	Δ / Y Conn	f (Hz)	P		I			T (Nm)	IE Class	% EFF at __ load				PF at __ load			I <sub>L</sub> /I <sub>N</sub> [pu]	T <sub>M</sub> /T <sub>N</sub> [pu]	T <sub>L</sub> /T <sub>N</sub> [pu]
			[kW]	[hp]	[A]	[RPM]	5/4FL			FL	3/4FL	1/2FL	FL	3/4FL	1/2FL				
415	Δ	50	45	60	77.3	1484	287.98	IE3	-	94.2	94.2	94.3	0.86	0.82	0.72	7.5	2.5	3.1	

Motor type	TCA	Degree of protection	IP 55
Enclosure	TEFC	Mounting type	IM B35
Frame Material	Cast Iron	Cooling method	IC 411
Frame size	225M	Motor weight - approx.	424 kg
Duty	S1	Gross weight - approx.	454 kg
Voltage variation *	± 10%	Motor inertia	0.7712 kgm <sup>2</sup>
Frequency variation *	± 5%	Load inertia	Customer to Provide
Combined variation *	10%	Vibration level	2.2 mm/s
Design	N	Noise level ( 1meter distance from motor)	65 dB(A)
Service factor	1.0	No. of starts hot/cold/Equally spread	2/3/4
Insulation class	F	Starting method	DOL
Ambient temperature	-20 to +50 °C	Type of coupling	Direct
Temperature rise (by resistance)	70 [ Class B ] K	LR withstand time (hot/cold)	15/30 s
Altitude above sea level	1000 meter	Direction of rotation	Bi-directional
Hazardous area classification	NA	Standard rotation	Clockwise form DE
Zone classification	NA	Paint shade	RAL 5014
Gas group	NA	Accessories	
Temperature class	NA	Accessory - 1	-
Rotor type	Aluminum Die cast	Accessory - 2	-
Bearing type	Anti-friction ball bearing	Accessory - 3	-
DE / NDE bearing	6313 C3 / 6213 C3	Terminal box position	RHS
Lubrication method	Regreasable	Maximum cable size/conduit size	1R x 3C x 50mm <sup>2</sup> /2 x M40 x 1.5
Type of grease	Shell Gadus S5 V100 or Equivalent	Auxiliary terminal box	NA

I<sub>L</sub>/I<sub>N</sub> - Locked Rotor Current / Rated Current

T<sub>M</sub>/T<sub>N</sub> - Breakdown Torque / Rated Torque

T<sub>L</sub>/T<sub>N</sub> - Locked Rotor Torque / Rated Torque

**NOTE**

All performance values at rated voltage and frequency.

All performance parameters are subjected to standard tolerance as per IEC 60034-1

\* Voltage, Frequency and combine variation are as per IEC60034-1

Technical data are subject to change. There may be discrepancies between calculated and name plate values.

Efficiency Standards	Europe	China	India	Aus/Nz	Brazil	Global IEC
	-	-	IS 12615 : 2018	-	-	-

Model No. TCA0452A3133GACD01

Enclosure	U (V)	$\Delta$ /Y Conn	f (Hz)	P (kW)	P (hp)	I (A)	n (RPM)	T (kgm)	T (Nm)	IE Class	Amb Temp (°C)	Duty	Elevation (m)	Inertia (kg·m <sup>2</sup> )	Weight (kg)
TFC	415	$\Delta$	50	45	60	77.3	1484	29.37	287.98	IE3	50	S1	1000	0.7712	424

**Motor Load Data**

Load Point	NL	1/4FL	1/2FL	3/4FL	FL	5/4FL
Current	A	27.3	32.5	44.2	59.2	77.3
Torque	Nm	0.0	71.4	143.2	215.4	288.0
Speed	r/min	1500	1496	1492	1488	1484
Efficiency	%	0.0	91.7	94.3	94.2	94.2
Power Factor	%	4.6	52.3	72.0	82.0	86.0

**Performance vs Load Chart**

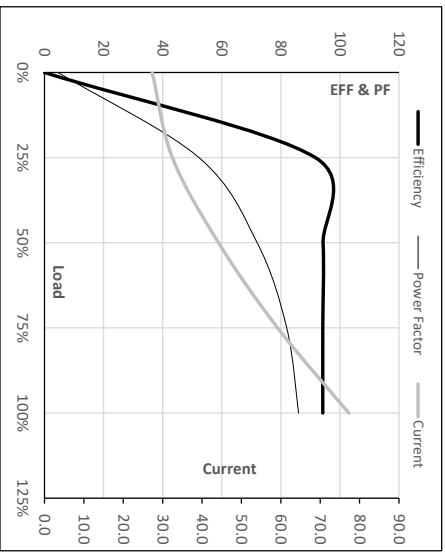

**Motor Speed Torque Data**

Load Point	LR	P-Up	BD	Rated	NL	
Speed	r/min	0	214	1365	1484	1500
Current	A	579.6	521.6	313.8	77.3	27.3
Torque	pu	2.5	2.1	3.1	1	0

**Starting Characteristics Chart**

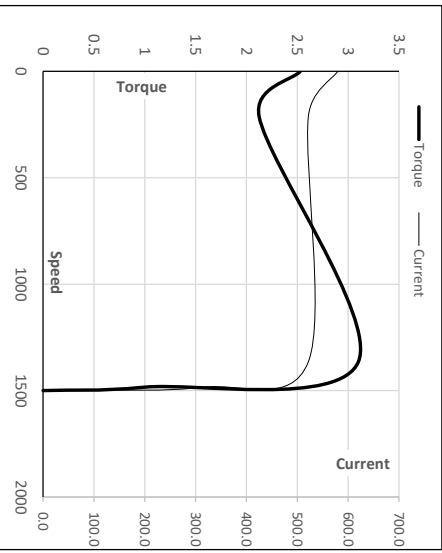

**NOTE** Refer data sheet for applicable standard and tolerances on performance parameters

Issued By  
Issued Date



Model No. TCA0452A3133GACD01

Enclosure	U	Δ / Y	f	P	P	I	n	T	T	IE	Amb	Duty	Elevation	Inertia	Weight
(V)	415	Δ	50	[kW]	[hp]	[A]	[rpm]	[kgm]	[Nm]	Class	[°C]	S1	[m]	[kg·m <sup>2</sup> ]	[kg]
TEFC				45	60	77.3	1484	29.34	287.98	IE3	50	S1	1000	0.7712	424

**Motor Speed Torque Data**

Load	FL	I <sub>1</sub>	I <sub>2</sub>	I <sub>3</sub>	I <sub>4</sub>	I <sub>5</sub>	LR	
TWT Hot	s	10000	56	38	35	30	25	15
TWT Cold	s	10000	110	75	70	50	40	30
Current	pu	1	2	3	4	5	5.5	7.5

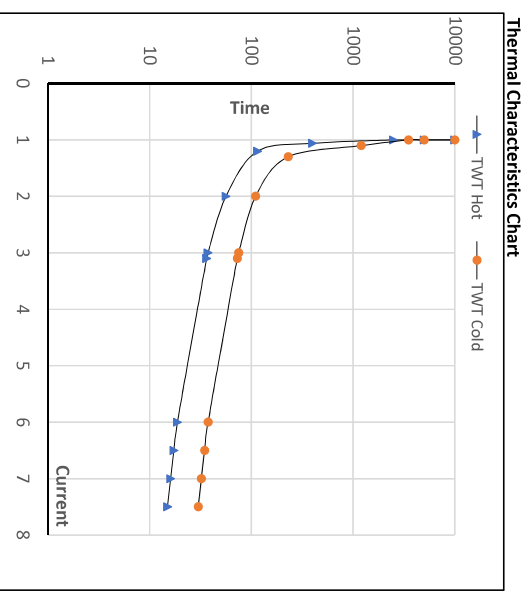

**NOTE** Refer data sheet for applicable standard and tolerances on performance parameters

Issued By  
Issued Date

