

# PRODUCT INFORMATION PACKET

Model No: TCA2P21A3111GACD01

Catalog No: TCA2P21A3111GACD01

2.2 kW General Purpose Low Voltage IEC Motor, 3 phase, 3000 RPM, 415 V, 90L Frame, TEFC  
Cast Iron IE3 Efficiency Motors





### Nameplate Specifications

Output HP	3 Hp	Output KW	2.2 kW
Frequency	50 Hz	Voltage	415 V
Current	4.0 A	Speed	2883 rpm
Service Factor	1	Phase	3
Efficiency	85.9 %	Power Factor	0.89
Duty	S1	Insulation Class	F
Frame	90L	Enclosure	Totally Enclosed Fan Cooled
Ambient Temperature	50 °C	Drive End Bearing Size	6205
Opp Drive End Bearing Size	6205	UL	No
CSA	No	CE	Yes
IP Code	55		

### Technical Specifications

Electrical Type	Squirrel Cage	Starting Method	Direct On Line
Poles	2	Rotation	Bi-Directional
Mounting	B3	Motor Orientation	Horizontal
Drive End Bearing	2z-C3	Opp Drive End Bearing	2z-C3
Frame Material	Cast Iron	Shaft Type	Keyed
Overall Length	332 mm	Frame Length	153 mm
Shaft Diameter	24 mm	Shaft Extension	50 mm
Assembly/Box Mounting	Top		
Outline Drawing	0209000395	Connection Drawing	8442000085

This is an uncontrolled document once printed or downloaded and is subject to change without notice. Date Created:06/01/2020

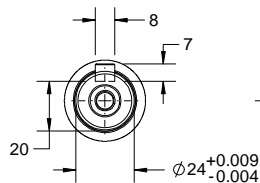
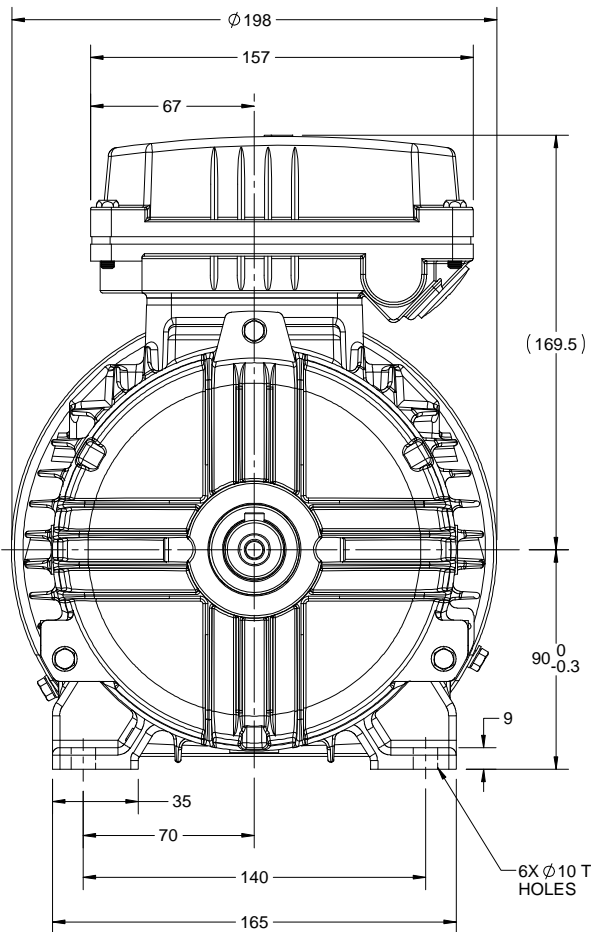

2X M20 CONDUIT ENTRY

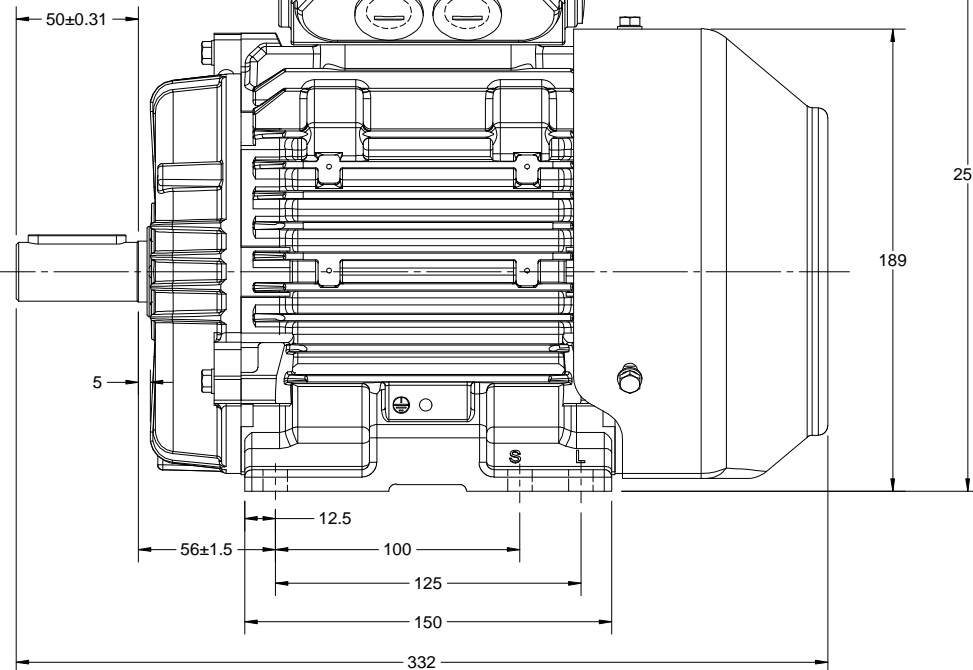

DRAWING REVISION D	REVISION BY A. KEETHA	DATE 26/06/2018
ECO ECO-0147359	APPROVED BY JAY	DATE 26/06/2018
ECO DESCRIPTION OUTLINE UPDATED AS PER NEW 3D STRUCTURING		
<small>COPYRIGHT REGAL BELDOT AMERICA, INC. ALL RIGHTS RESERVED.          PROPRIETARY AND CONFIDENTIAL INFORMATION - THIS DOCUMENT IS THE PROPERTY OF          REGAL BELDOT AMERICA, INC. (OWNER) AND CONTAINS OWNER'S PROPRIETARY          INFORMATION. ANY PERSON, CORPORATION OR OTHER FIRM RECEIVING IT IS DEEMED,          BY RECEIVING IT, TO AGREE THAT IT, AND/OR ANY PART OF IT, SHALL NOT BE DISCLOSED          TO ANY PERSON, CORPORATION OR OTHER ENTITY, DUPLICATED, AND/OR USED, EXCEPT          AS EXPRESSLY APPROVED IN WRITING IN ADVANCE BY OWNER. THIS DOCUMENT SHALL          BE RETURNED TO OWNER UPON REQUEST. IT MAY BE SUBJECT TO CERTAIN          RESTRICTIONS UNDER APPLICABLE EXPORT CONTROL LAWS AND REGULATIONS.</small>		

DRAWN BY SMAR
DATE 1/09/13
APPROVED BY JAY
DATE 1/09/13
REFERENCE

**marathon**  
Motors

DESCRIPTION  
**OUTLINE**  
90 FR- B3 MTG. MOTOR TYPE:TCA

MATERIAL PROCESS/FINISH

THIRD ANGLE PROJECTION

SIZE B DRAWING NUMBER  
**0209000395**

SHEET  
1 OF 1

COPYRIGHT REGAL BELOIT AMERICA, INC. ALL RIGHTS RESERVED. **Unapproved Copy**  
 PROPRIETARY AND CONFIDENTIAL INFORMATION - THIS DOCUMENT IS THE PROPERTY OF  
 REGAL BELOIT AMERICA, INC. ("OWNER") AND CONTAINS OWNER'S PROPRIETARY  
 INFORMATION. ANY PERSON, CORPORATION OR OTHER FIRM RECEIVING IT IS DEEMED  
 BY RECEIVING IT TO AGREE THAT IT AND/OR ANY PART OF IT SHALL NOT BE DISCLOSED  
 TO ANY PERSON, CORPORATION OR OTHER ENTITY, DUPLICATED, AND/OR USED, EXCEPT  
 AS EXPRESSLY APPROVED IN WRITING IN ADVANCE BY OWNER. THIS DOCUMENT SHALL  
 BE RETURNED TO OWNER UPON REQUEST. IT MAY BE SUBJECT TO CERTAIN  
 RESTRICTIONS UNDER APPLICABLE EXPORT CONTROL LAWS AND REGULATIONS.

DRAWING REVISION	REVISION BY	DATE
A	SN	13/01/2017
ECO-0116390	APPROVED BY SBD	DATE 13/01/2017
ECO DESCRIPTION NEW DRAWING RELEASE		

GEOMETRIC TOLERANCE		
LINEAR DIM	>0-6	±0.1
	>6-30	±0.2
	>30-120	±0.3

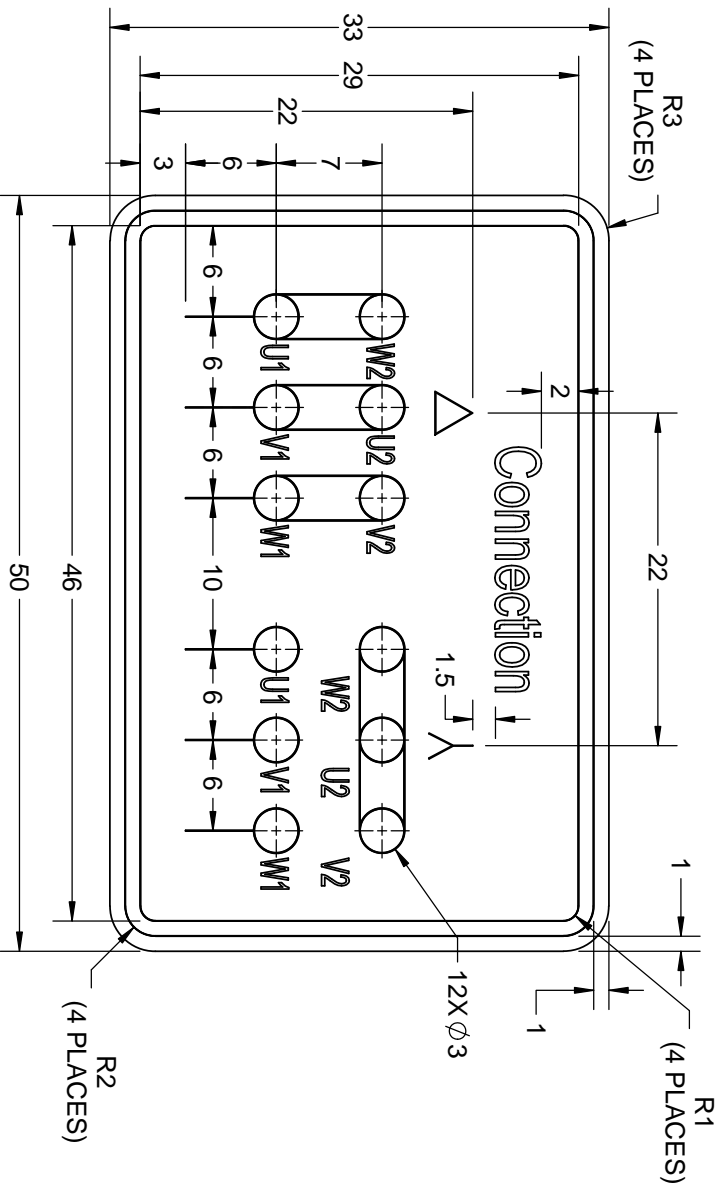

- NOTES:
1. PRESSURE-SENSITIVE ADHESIVE COATED PAPER ON THE BACK OF SELF-ADHESIVE.
  2. AT THE END OF YELLOW, WORDS, SYMBOLS, LETTERS ARE BLACK, BORDER IS BLACK.
  3. THE TOLERANCE OF THE LINEAR SIZE OF THE TOLERANCE WITHOUT THE TOLERANCE BY THE TABLE.

8WD.442.2017

DRAWN BY SN		DESCRIPTION <b>REGAL</b> <sup>TM</sup> Regal Beloit America, Inc. CONN DIAGRAM-NAMEPLATE	
DATE 16/12/2016	APPROVED BY SBD	DATE 16/12/2016	MATERIAL
REFERENCE	PROCESS/FINISH	SIZE A	DRAWING NUMBER 8442000085
THIRD ANGLE PROJECTION		SHEET 1 OF 1	

Model No. TCA2P21A3111GACD01

U (V)	Δ / Y Conn	f (Hz)	P		I		n [RPM]	T [Nm]	IE Class	% EFF at __ load			PF at __ load			I <sub>L</sub> /I <sub>N</sub> [pu]	T <sub>M</sub> /T <sub>N</sub> [pu]	T <sub>L</sub> /T <sub>N</sub> [pu]	
			[kW]	[hp]	[A]	[A]				5/4FL	FL	3/4FL	1/2FL	FL	3/4FL				1/2FL
415	Y	50	2.2	3.0	4.0	2883	7.42		IE3	-	85.9	85.9	85.1	0.89	0.84	0.73	7.7	3.5	3.4

Motor type	TCA	Degree of protection	IP 55
Enclosure	TEFC	Mounting type	IM B3
Frame Material	Cast Iron	Cooling method	IC 411
Frame size	90L	Motor weight - approx.	28.5 kg
Duty	S1	Gross weight - approx.	29.5 kg
Voltage variation *	± 10%	Motor inertia	0.0030 kgm <sup>2</sup>
Frequency variation *	± 5%	Load inertia	Customer to Provide
Combined variation *	10%	Vibration level	1.6 mm/s
Design	N	Noise level ( 1meter distance from motor)	63 dB(A)
Service factor	1.0	No. of starts hot/cold/Equally spread	2/3/4
Insulation class	F	Starting method	DOL
Ambient temperature	-20 to +50 °C	Type of coupling	Direct
Temperature rise (by resistance)	70 [ Class B ] K	LR withstand time (hot/cold)	6/10 s
Altitude above sea level	1000 meter	Direction of rotation	Bi-directional
Hazardous area classification	NA	Standard rotation	Clockwise form DE
Zone classification	NA	Paint shade	RAL 5014
Gas group	NA	Accessories	
Temperature class	NA	Accessory - 1	-
Rotor type	Aluminum Die cast	Accessory - 2	-
Bearing type	Anti-friction ball bearing	Accessory - 3	-
DE / NDE bearing	6205-2Z / 6205-2Z	Terminal box position	TOP
Lubrication method	Greased for life	Maximum cable size/conduit size	1R x 3C x 10mm <sup>2</sup> /2 x M20 x 1.5
Type of grease	NA	Auxiliary terminal box	NA

I<sub>L</sub>/I<sub>N</sub> - Locked Rotor Current / Rated Current

T<sub>M</sub>/T<sub>N</sub> - Breakdown Torque / Rated Torque

T<sub>L</sub>/T<sub>N</sub> - Locked Rotor Torque / Rated Torque

**NOTE**

All performance values at rated voltage and frequency.

All performance parameters are subjected to standard tolerance as per IEC 60034-1

\* Voltage, Frequency and combine variation are as per IEC60034-1

Technical data are subject to change. There may be discrepancies between calculated and name plate values.

Efficiency Standards	Europe	China	India	Aus/Nz	Brazil	Global IEC
	-	-	IS 12615 : 2018	-	-	-

Model No. TCA2P21A3111GACD01

Enclosure	U (V)	Δ/Y Conn	f (Hz)	P (kW)	P (hp)	I (A)	n (RPM)	T (kgm)	T (Nm)	IE Class	Amb Temp (°C)	Duty	Elevation (m)	Inertia (kg·m <sup>2</sup> )	Weight (kg)
TFC	415	Y	50	2.2	3.0	4.0	2883	0.76	7.42	IE3	50	S1	1000	0.003	28.5

**Motor Load Data**

Load Point	NL	1/4FL	1/2FL	3/4FL	FL	5/4FL
Current	A	1.6	1.9	2.4	3.2	4.0
Torque	Nm	0.0	1.8	3.6	5.5	7.4
Speed	r/min	3000	2972	2946	2916	2883
Efficiency	%	0.0	79.0	85.1	85.9	85.9
Power Factor	%	11.4	52.6	73.0	84.0	89.0

**Performance vs Load Chart**

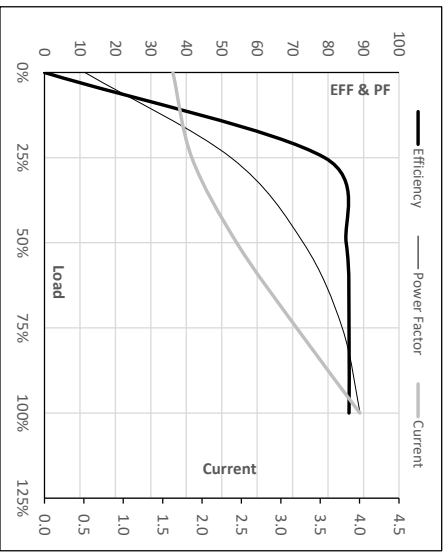

**Motor Speed Torque Data**

Load Point	LR	P-Up	BD	Rated	NL	
Speed	r/min	0	600	1973	2883	3000
Current	A	30.8	27.7	19.7	4.0	1.6
Torque	pu	3.5	3.0	3.4	1	0

**Starting Characteristics Chart**

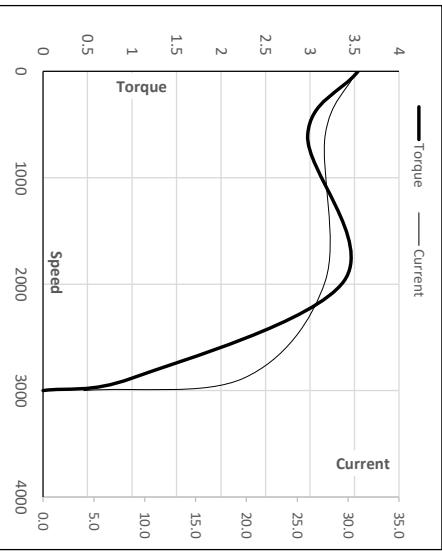

**NOTE** Refer data sheet for applicable standard and tolerances on performance parameters

Issued By  
Issued Date

Model No. TCA2P21A3111GACD01

Enclosure	U (V)	Δ / Y Conn	f (Hz)	P [kW]	P [hp]	I [A]	n [rpm]	T [kgm]	T [Nm]	IE Class	Amb [°C]	Duty	Elevation [m]	Inertia [kg·m <sup>2</sup> ]	Weight [kg]
TEFC	415	Y	50	2.2	3.0	4.0	2883	0.76	7.42	IE3	50	S1	1000	0.0030	28.5

**Motor Speed Torque Data**

Load	FL	I <sub>1</sub>	I <sub>2</sub>	I <sub>3</sub>	I <sub>4</sub>	I <sub>5</sub>	LR	
TWT Hot	s	10000	23	15	14	11	9	6
TWT Cold	s	10000	45	26	24	21	15	10
Current	pu	1	2	3	4	5	5.5	7.7

**Thermal Characteristics Chart**

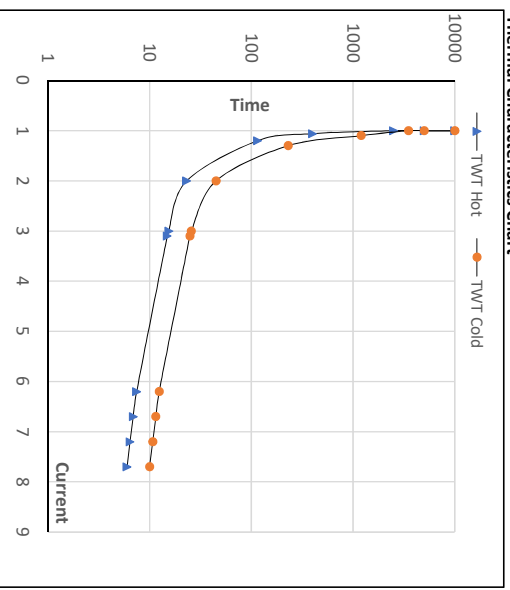

**NOTE** Refer data sheet for applicable standard and tolerances on performance parameters

Issued By  
Issued Date

